

Gooch & Housego

Luminance, Spectral Radiance, & Correlated Color Temperature Calibration at 6500 K for the OL 455 Series Equipped with D65 Spectral Shaping Filter

The OL 455 Series may be calibrated with a D65 Spectral Shaping Filter for luminance, spectral radiance and correlated color temperature at 6500 K relative to standards supplied by the National Institute of Standards and Technology (NIST). The estimated uncertainty in correlated color temperature is ± 50 K. The uncertainty of the luminance is estimated to be less than ± 3 % relative to the NIST photometric scale.

The D65 Filter for a 4-Inch, 6-Inch and 8-Inch Diameter Integrating Sphere typically consists of two glass filters (an additional filter is used for a 12-Inch or 18-Inch diameter integrating sphere). The uncalibrated D65 Filter is supplied without data or a lamp current setting and consists of the same glass (and thickness) that is currently being used to obtain a correlated color temperature of 6500 K. To prevent breakage, the fL level is typically limited to approximately 300 fL with the D65 filter installed. Higher fL levels have been calibrated upon request. Note: Due to filter availability, the filters used and the resulting spectral distribution may change without notice.

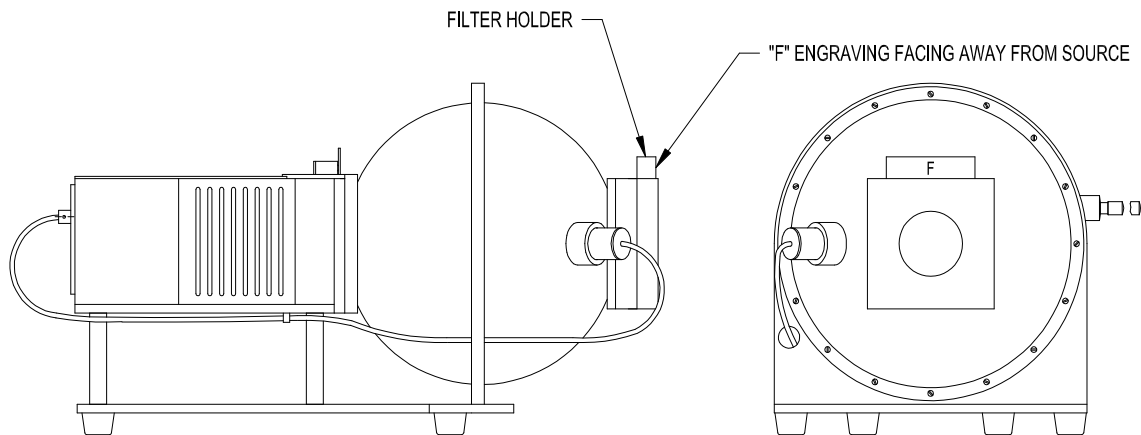

Contact: orlandosales@goochandhousego.com

www.GHinstruments.com

As part of our policy of continuous product improvement, we reserve the right to change specifications at any time

Information Sheet 77 / Rev 3-14
Page 1 of 2



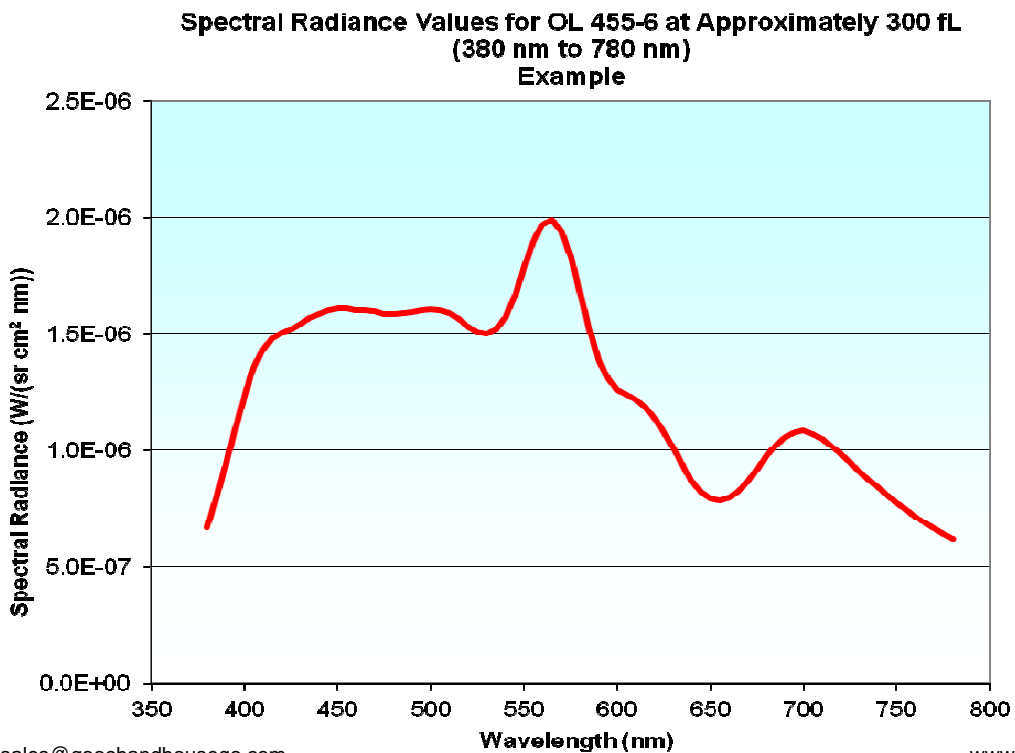
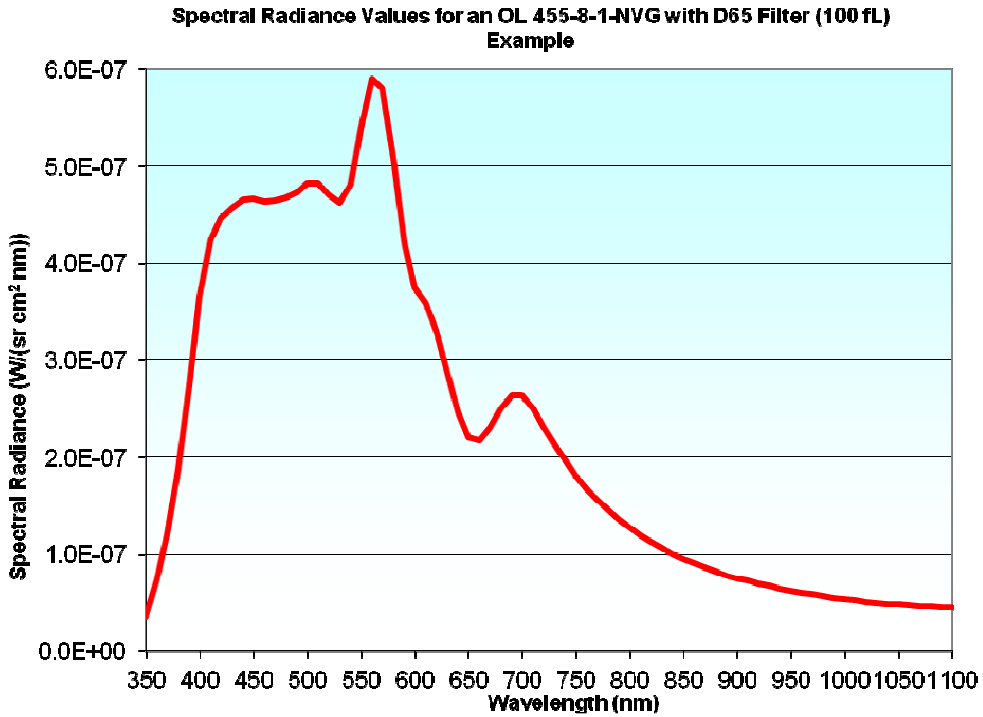

Contact: orlqandosales@goochandhousego.com

www.GHinstruments.com

As part of our policy of continuous product improvement, we reserve the right to change specifications at any time

